

THIS DRAWING IS UNPUBLISHED. RELEASED FOR PUBLICATION -  
 © COPYRIGHT - BY TYCO ELECTRONICS CORPORATION. ALL RIGHTS RESERVED.

LOC	DIST	REVISIONS					
DW	-	P	LTR	DESCRIPTION	DATE	DWN	APVD
		B		ADD P/N: 6-1, ECR-07-000493	09MAR07	SH	WK

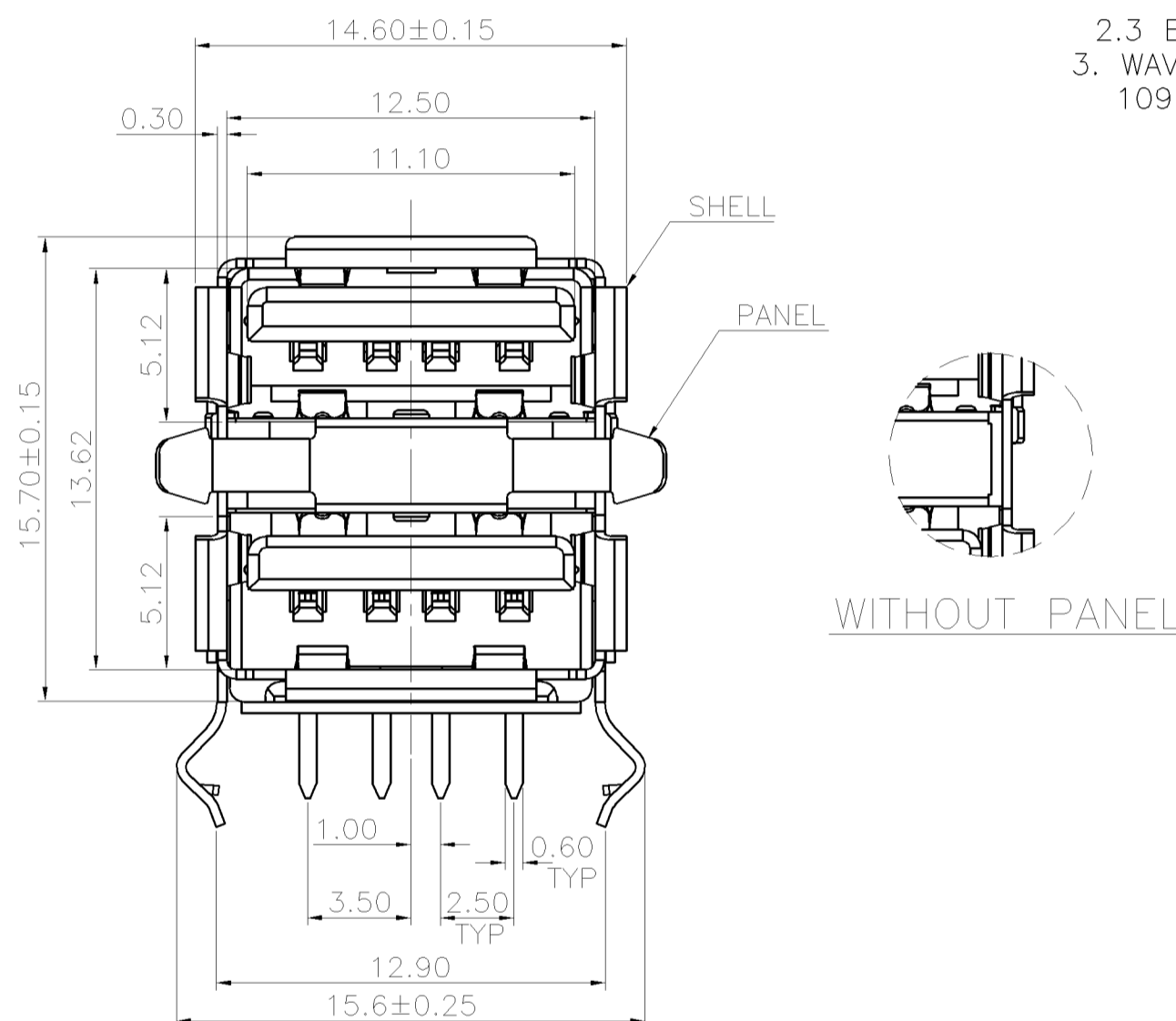
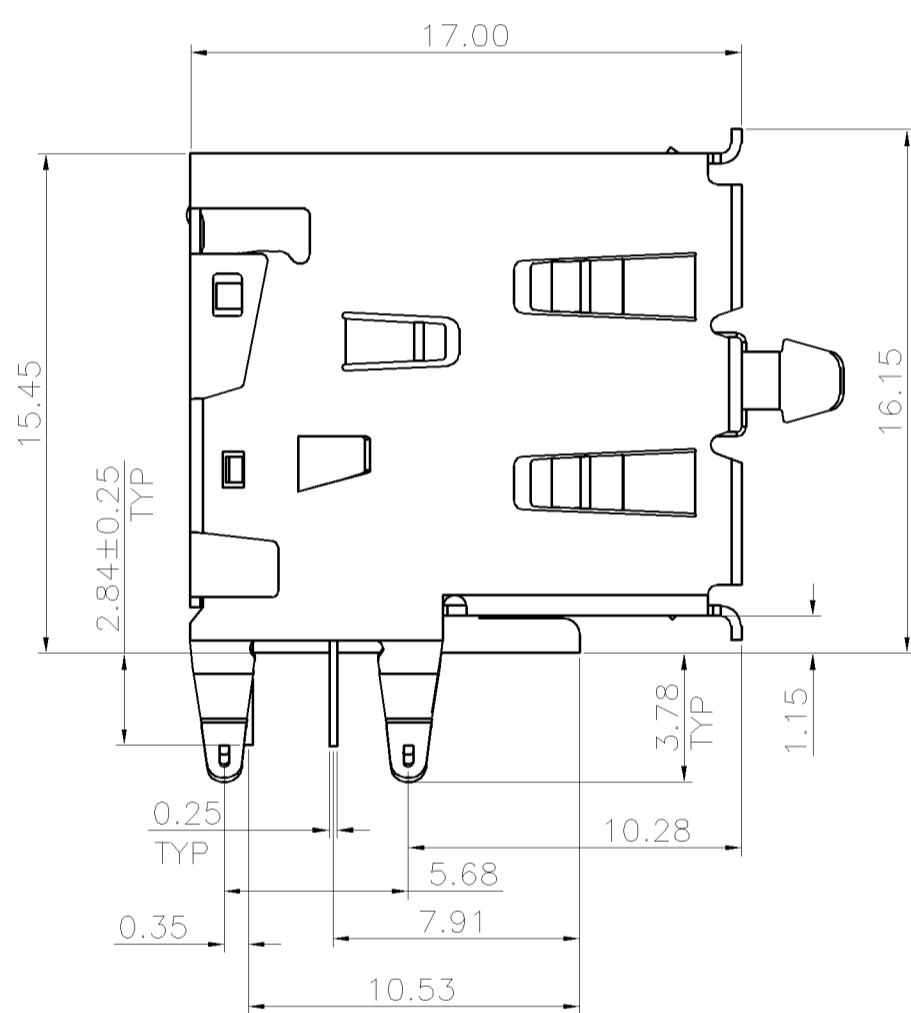
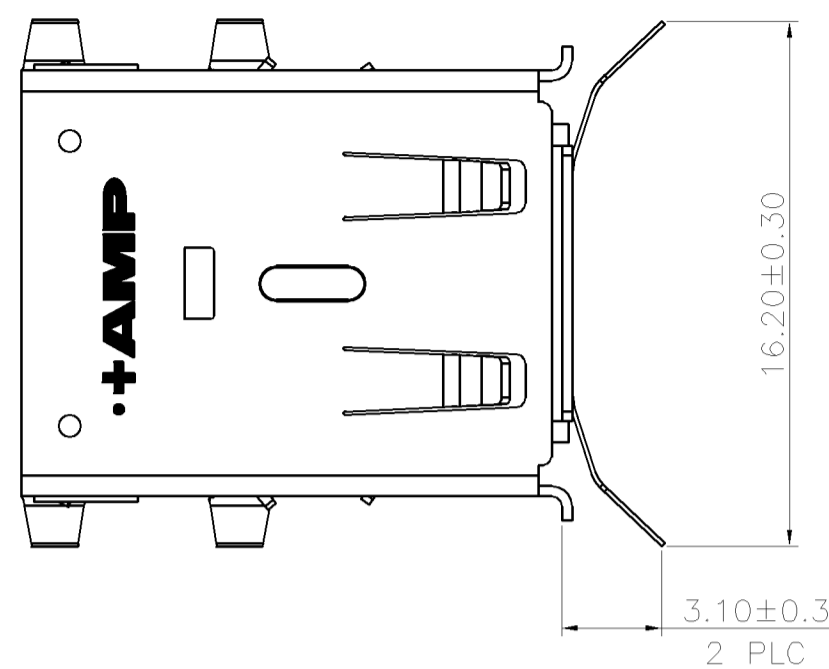

- NOTES :
- MATERIAL :
    - HOUSING: NYLON46 W/ 30%G/F, UL94V-0, COLOR:SEE TABLE
    - CONTACTS: PHOSPHOR BRONZE
    - SHELL : BRASS
    - MIDDLE CLIP : STAINLESS STEEL
    - BACK COVER : BRASS
  - FINISH:
    - CONTACT: GOLD PLATING (SEE TABLE) ON CONTACT AREA, 3.04µm[120µ"] MIN. MATTE TIN PLATING ON SOLDER TAILS, 1.27µm[50µ"] MIN. NICKEL UNDERPLATING OVERALL.
    - SHELL: 3.04µm[120µ"] MIN. BRIGHT TIN PLATING, 1.27µm[50µ"] MIN. NICKEL UNDERPLATED OVERALL.
    - BACK COVER: 1.27µm[50µ"] MIN. NICKEL PLATING OVERALL.
  - WAVE SOLDER CAPABLE TO 265°C PER TYCO TEST SPEC. 109-202, CONDITION B.

BLUE 285C	5.0g	W/	W/	G/F	6-1734022-1
	4.3g	W/O	W/O	30u" MIN.	5-1734022-2
	5.0g	W/O	W/	30u" MIN.	5-1734022-1
	5.0g	W/	W/	30u" MIN.	4-1734022-1
	4.8g	W/O	W/	15u" MIN.	3-1734022-1
	4.8g	W/	W/	15u" MIN.	2-1734022-1
	4.3g	W/O	W/O	G/F	1-1734022-2
	4.8g	W/O	W/	G/F	1-1734022-1
	4.5g	W/	W/O	G/F	1734022-2
	5.0g	W/	W/	G/F	1734022-1
HSG COLOR	NET WEIGHT	PANEL	BACK COVER	GOLD PLATED	PART NUMBER

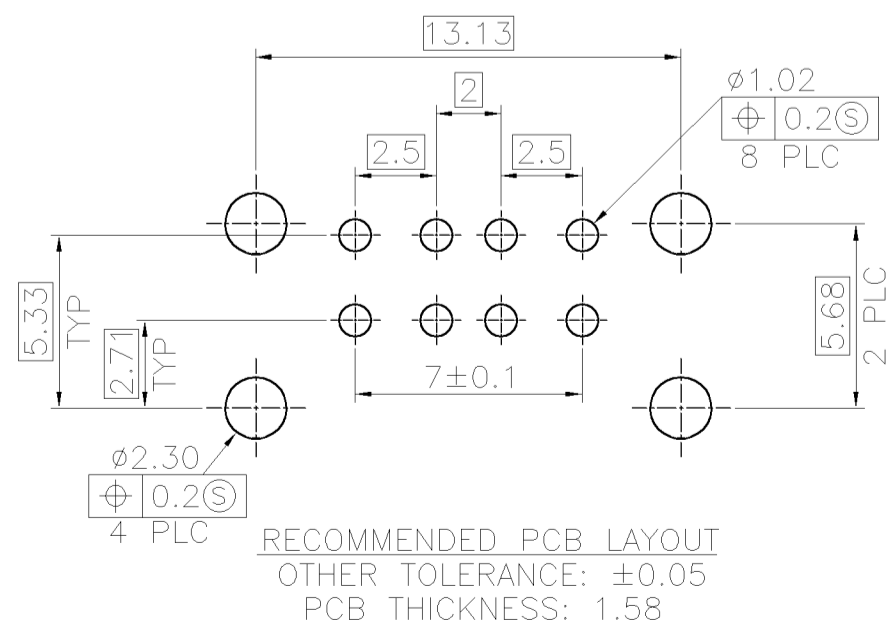

THIS DRAWING IS A CONTROLLED DOCUMENT.		DWN	S. HOU	09MAR2007	 Tyco Holdings (Bermuda) VII Ltd. Taiwan Branch		
DIMENSIONS: MM		CHK	W.J. KE	09MAR2007			
TOLERANCES UNLESS OTHERWISE SPECIFIED:		APVD	W.J. KE	09MAR2007			
0 PLC ± 0.50 1 PLC ± 0.30 2 PLC ± 0.20 3 PLC ± 0.05 4 PLC ± - ANGLES ± 3°		PRODUCT SPEC		NAME			
MATERIAL SEE NOTE		FINISH SEE NOTE		108-1586	USB STACKED, A TYPE, R/A, DIP		
QUALIFICATION TEST REPORT		--		SIZE	CAGE CODE	DRAWING NO	RESTRICTED TO
CUSTOMER DRAWING		WEIGHT SEE TABLE		A3	00779	C-1734022	---
SCALE		---		SHEET		1 OF 2	REV B

THIS DRAWING IS UNPUBLISHED. RELEASED FOR PUBLICATION  
 © COPYRIGHT BY TYCO ELECTRONICS CORPORATION. ALL RIGHTS RESERVED.

LOC DW	DIST —	REVISIONS			
P	LTR	DESCRIPTION	DATE	DWN	APVD
		SEE SHEET 1.			

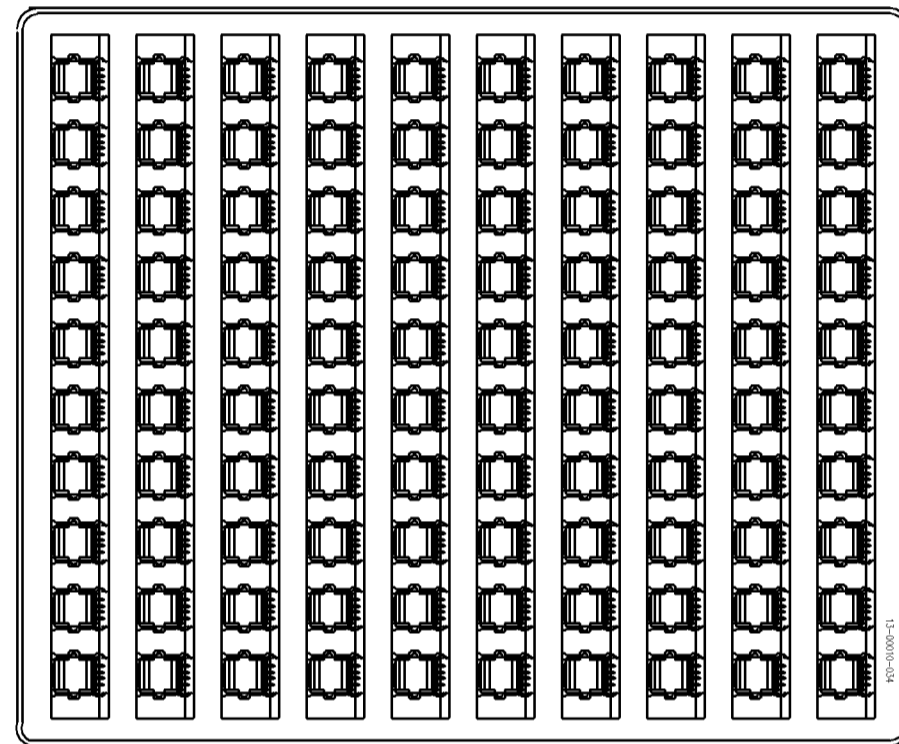
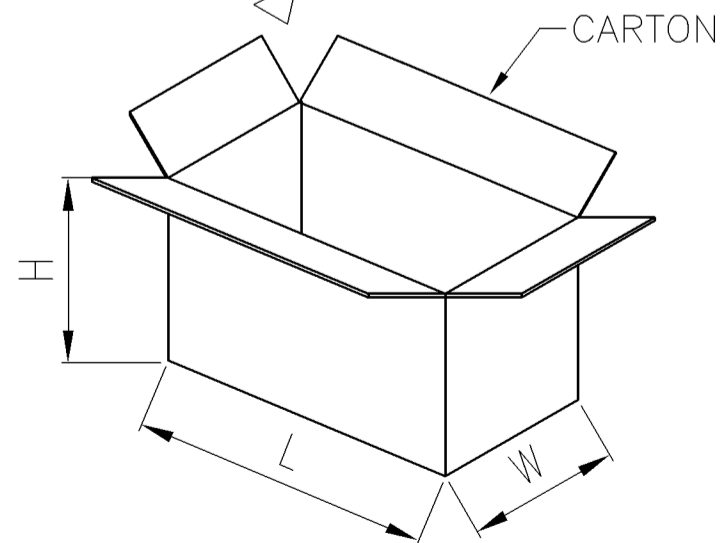
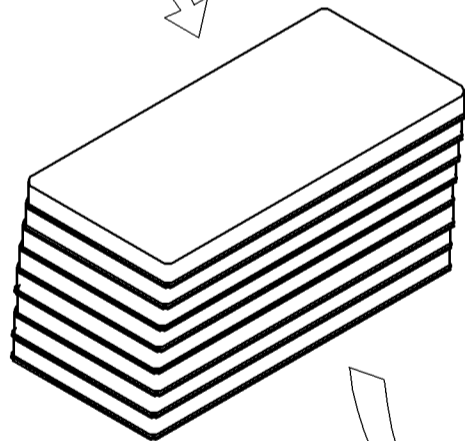
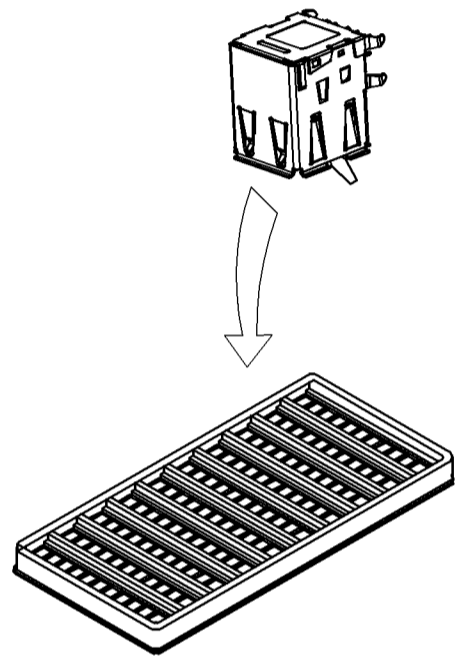
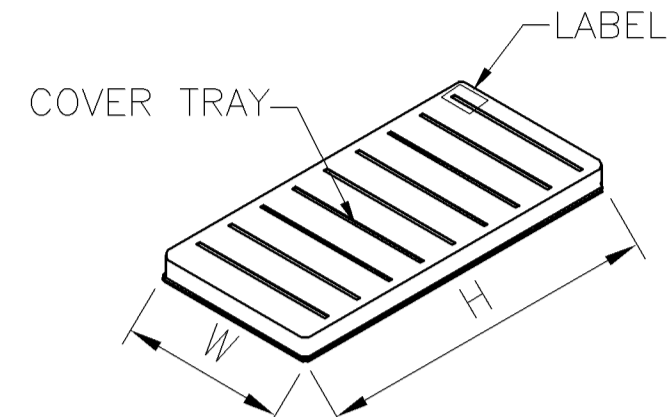

- NOTES :
- DIMENSION :
    - 1.1 TRAY : L=330, W=275, H=25(W/ PANEL)  
 TRAY : L=330, W=275, H=20(W/O PANEL)
    - 1.2 SHIPPING CARTON : L=350, W=290, H=240
  - QUANTITY :
    - 2.1 PRIMARY PACKING: 100 PCS/TRAY
    - 2.2 SECONDARY PACKING: 8 TRAYS/CARTON(800PCS) WITHOUT PANEL
    - 2.1 PRIMARY PACKING: 100 PCS/TRAY
    - 2.2 SECONDARY PACKING: 10 TRAYS/CARTON(1000PCS)
  - WEIGHT :
    - 3.1 NET WEIGHT : 3.6Kg
    - 3.2 GROSS WEIGHT : 5.8Kg
    - 3.1 NET WEIGHT : 4.5Kg
    - 3.2 GROSS WEIGHT : 6.5Kg

THIS DRAWING IS A CONTROLLED DOCUMENT.		DWN S. HOU	09MAR2007	<b>tyco</b> Tyco Holdings (Bermuda)	
DIMENSIONS: MM		CHK W.J. KE	09MAR2007	<b>Electronics</b> VII Ltd. Taiwan Branch	
TOLERANCES UNLESS OTHERWISE SPECIFIED:		APVD W.J. KE	09MAR2007	NAME	
0 PLC ± -		PRODUCT SPEC		USB STACKED, A TYPE, R/A, DIP	
1 PLC ± -		APPLICATION SPEC		SIZE	RESTRICTED TO
2 PLC ± -		WEIGHT		A3	—
3 PLC ± -		CUSTOMER DRAWING		CAGE CODE	
4 PLC ± -		SCALE		00779	
ANGLES ± -		SHEET		DRAWING NO	
FINISH		REV		G-1734022	
MATERIAL		2 OF 2			